

IPC-7132

Cost-effective Wallmount Chassis for ATX/uATX Motherboard



CE FCC

Features

- Supports ATX/uATX motherboard
- Shockproof drive bay for one 5.25" ODD and three 3.5" HDDs
- Thumb-screw for top cover easy opening
- Bidirectional option to mount chassis on wall or workbench
- Two front access USB ports
- Low noise PWM controlled

Specifications

Disk Drive Bay	3.5"	External	Internal
	5.25"	1	2
Cooling	Fan	1 (12 cm/82 CFM)	-
	Air Filters	Yes	-
Front I/O interface	USB 2.0	2	-
Miscellaneous	LED Indicators	Power, HDD	-
	Control	Power Switch, System Reset Button	-
	Rear panel	4x USB, 2x DB-9, 1x LPT port	-
Environment	Temperature	Operating	Non-operating
	Humidity	0 ~ 40 °C (32 ~ 104 °F)	-20 ~ 60 °C (-4 ~ 140 °F)
	Vibration (5-500 Hz)	10 ~ 85 % @ 40 °C, non-condensing	10 ~ 95 % @ 40 °C, non-condensing
	Shock	1 Grms	2 G
	Weight	10 G (with 11 ms duration, half sine wave)	-
Physical Characteristics	Dimensions (W x H x D)	200 x 330 x 430 mm (7.9" x 13" x 16.9")	-
	Weight	9.96 kg (21.93 lb)	-

Front View

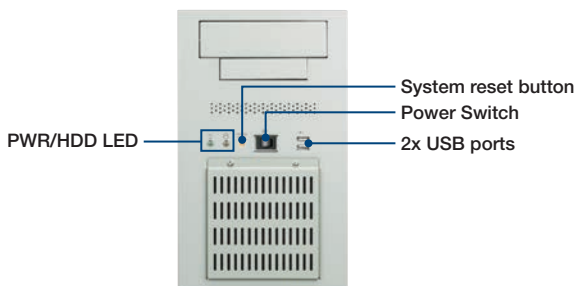

Rear View

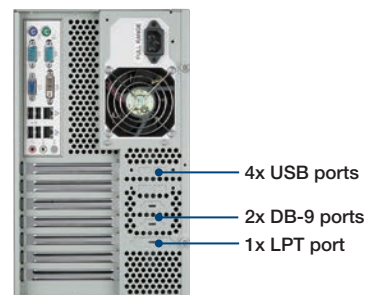

Inside View

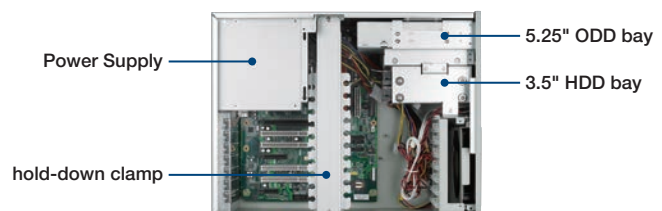

Easy-to-maintain cooling fan

Dimensions

Unit: mm [inch]

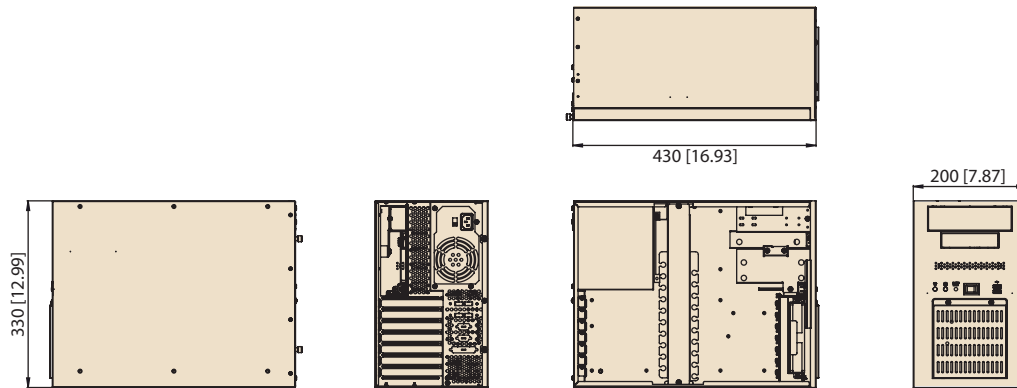

Installation

Unit: mm [inch]

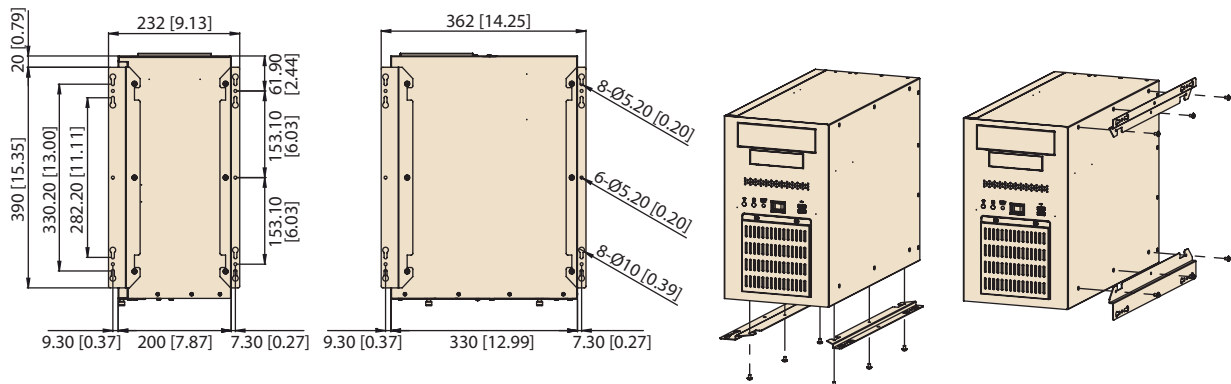

Ordering Information

Model Name	Power Supply	Wattage	Switch Type
IPC-7132MB-30B	PS8-300ATX-ZBE	300W	ATX
IPC-7132MB-50B	PS8-500ATX-BB	500W	ATX

Optional Accessories

Part Number	Description
IPC-DT-3120E	Mobile HDD tray for dual 2.5" SATA HDDs